



PIONEER NUTS **& BOLTS PVT. LTD.**

(COMMITTED FOR QUALITY PRODUCTS)

- ▶ AN ISO 9001 : 2015 CERTIFIED COMPANY
- ▶ ISO 45001 - 2018
- ▶ ISO / IEC 17025 - 2017 IN HOUSE LAB

TUFF THE FUTURE! CONTRIBUTING IN
CONSTRUCTING THE INDUSTRY OF

TOMORROW
BUILDING NEW INDIA

We are manufacturing all types of fastener products with latest technology, hi-tech machinery & equipments with trained manpower to meet the quality objectives and customer satisfaction.



FOUNDER OF THE COMPANY

LATE : SHRI JOGINDER KUMAR GUPTA
29.05.1937 - 03.03.2018

Our Founder Vision and Mission as below

“ Lokah Samastah Sukhino Bhavantu”

These ancient words mean ‘ May all the people in this universe
live with happiness and prosperity’

**At Pioneer we strives towards happiness of all stakeholders where customers
Satisfaction is old word, we work hard on customer delight.**

Our Founder was very clear regarding quality. He commonly used the word
‘गलत करने से ना करना अच्छा है’ ‘ It is better not to do instead of doing wrong’

Based on this mission and vision we 24x7 work hard to match our customer’s requirements and from
the last more than 25 years our customers encourage us to keep this model up.

TUFF is a quality brand conceived and distributed by Pioneer Nuts & Bolt Pvt. Ltd. Our vision to meet
industry demands for a range of quality fasteners backed by a dependable service. Twenty six years on,
this vision is still paramount, a service that delivers a range of fasteners on time, every time.



Welcome!

AT
PIONEER NUTS & BOLT PVT. LTD.

Message of Managing Director

Dear customer I like to thank you from core of my heart for giving us opportunity to supply our fasteners for your prestigious projects.

I am fully confident that based on our commitment for customer delight, you will be definitely satisfied with our products & services.

Based on intense hard work and R & D from last 30 years, we understand metals & its metallurgical properties better & our products stand fully complied with National / International check parameters. Dear customer if you can mail us at sales@tuffbolt.com any of your experience, query, doubt or suggestion. I will be highly thankful.

With best Regards.

Archana Gupta

ARCHANA GUPTA

(Managing Director)

Pioneer Nuts & Bolts Pvt. Ltd.

Important Note: We at Pioneer are working more than fasteners like Fabrication work, Forging & Machining components those are with complex mechanical requirements. You can share if anything like this we can do for your projects.

HOW AT PIONEER WE DEFINE FASTENERS :

“Fastener is a product base on which bulk loads stand with confidence for years & years”.

Dear customer to match the above statement we at Pioneer work through different tests carried out on our products, some are as below;

TESTS OF BOLTS / NUTS / WASHERS

Tensile Test - Tensile strength, Lower Yield strength, Upper Yield strength, 0.2% proof stress / yield stress, Percentage Elongation after fracture, Percentage Reduction in area after fracture, Elevated tensile test - Tensile strength, Proof stress / Yield stress, Percentage Elongation after fracture, Percentage Reduction in area after fracture ;

Tensile strength under Wedge loading, Tensile strength under axially loading, Proof load test (Bolt) – measuring permanent extension, Proof load (Nut);

Rockwell Hardness test scale “C”, Rockwell Hardness test scale “B”, Brinell hardness test using Tungsten ball– HBW, Vickers hardness test – HV, MicroVickers hardness test, Maximum Surface hardness test – Micro Vickers hardness (HV0.3) method, Core hardness test - MicroVickers hardness (HV0.3) method;

Decarburization test – microscopic method, Total depth of ferritic decarburization, Partial depth of decarburization, Decarburization test – Micro Vickers hardness method, detection of decarburization, Measurement of Non-decarburized zone “E”, Carburization test - microVickers hardness method, Total case of depth – MicroVickers hardness method, Total case of depth – Microscopic method, Hardness after retempering;

Torque test, Torsional test, Antiseizing test, Preload suitability test – Tension Vs Clamp force, Preload test – Tension (TC bolt);

Impact test “V” & “U” notch, Impact Test at room temperature, Impact Test at -20°C temperature, Impact Test at -0°C temperature, Impact Test at -101°C temperature, Impact Test at -196°C temperature, Cantilever test, Shear test, Head soundness test, Hydrogen embrittlement test;

Lock bolt - Clamp load test (Lock Bolt), Tensile load test (Lock Bolt), Shear load test (Lock Bolt), Bend Test, Fatigue Test (Endurance Limit), Permanent Set Test (Spring Washer), Permanent load Test (Spring Washer), Twist Test (Spring Washer), Compression Test (Direct Tension Indicator), Prevailing Torque Test – Prevailing Torque Nut,

Surface finish - Coating thickness test, Mass of coating test, Uniformity of coating test, Adhesion of coating test, Surface integrity test (Magnetic Particle test – MPI), Salt spray test

Inclusion rating test – to check homogeneity of the raw material, Macro etch test - to check internal integrity of raw material, Grain size test – to check grain size of the raw material, Grain size test – to check homogeneity of structure and martensite greater than 90% of heat treated product, Optical Emission Spectrometry Test.

Thread Profile Test under Profile Projector - Thread pitch measurement, Thread angle measurement, Thread pitch measurement, Thread radius measurement, Under head radius measurement, Chamfer angle measurement, Chamfer length measurement, Pitch measurement – thread pitch gauge, Thread Plug gauge test for Nut, Thread Ring gauge test for Bolt, Impact sample profile measurement - Notch angle, Notch depth, Notch radius, Notch centre, Plane of symmetry measurements.

(Note: We also carry test based on particular fitment or assembly as per customer requirement like fatigue test / endurance limit).



**WE HAVE MANUFACTURED
MILLIONS OF FASTENERS IN
MORE THAN 25 YEARS AND
MOST OF THESE ARE USED
IN INDIA'S DIFFERENT
PRESTIGIOUS PROJECTS,
SOME ARE AS BELOW;**



NUCLEAR POWER PROJECTS

Our fasteners Used at Department of Atomic energy

3

JAMNAGAR REFINERY

**ONE OF THE LARGEST REFINERY
IN THE WORLD**



Power Sector



Vande Bharat train (T-18)



Railway (Engines, Boggies, Coaches)



Bridge



Metros (Infrastructure & more)



Solar Energy



Aerospace



Automobile Vehicle Factory Jabalpur



Earth Moving Machines / Cranes



Fabrication work



Home (Antilia Mumbai)



HOW OUR CUSTOMER / STAKEHOLDERS RATE US :

- (i) Committed for on time delivery
- (ii) Ethical company
- (iii) Zero tolerance in Quality
- (iv) Replies / Solution for queries instantly
- (v) Sales after service excellent
- (vi) Professional approach
- (vii) Developing new products
- (viii) Respect for human values
- (ix) Put hard on R & D work
- (x) Enriched with all testing facilities
- (xi) Always updated with latest version of standards
- (xii) Well planned testing and each testing facility available under
NABL inhouse laboratory

At Pioneer our principle is “safety first” and further we are working on principle “it is better not to do instead of doing wrong”.

Based on metals and metallurgical experience of more than 30years our management has in depth knowledge for processing of metals. We are also associated technically with International Fastener Institute Cleveland. Our management has also personally attended seminars on crucial subjects for different fastener requirements. This help to keep us update on the subject matter.

Further our customers like Defence & Railways has given us opportunity to develop fasteners those were imported from Germany in early 1990's based on quality requirement we visited USA, Japan & Germany to understand the processes and technically collaborate to develop these items.

DEAR USER

Please Find Herein Fitment Instruction/ Guidance to Ensure Your Safety and Good Fitment of fasteners ensuring long life:-

BOLTING THEORY

FOLLOWING MUST BE DONE TO ENSURE GOOD FITMENT AND SAFETY OF USER:-

A. Proper Torque: - The torque values for tightening of nuts & bolts must be optimal. Too much torque values can lead to stress in joints further more than required torque values will shorten the life of fasteners. Further if we cross tensile limit of bolt it could ultimately lead to failure of joints.

At TUFF our fasteners support higher torque leading to longer life of fasteners.

B. Proper Lubrication: - Proper lubrication would insure that there is minimal friction in joints leading to proper tightening, achieving required coefficient of friction and ultimately increasing the life of fasteners & joints.

C. Rust Preventing: - Fasteners should be properly covered and must not be subject to high moisture and water prone areas as this could lead to more & more rusting of fasteners ultimately severing the life of fasteners.

UNIFORM PRELOAD (RESIDUAL LOAD)

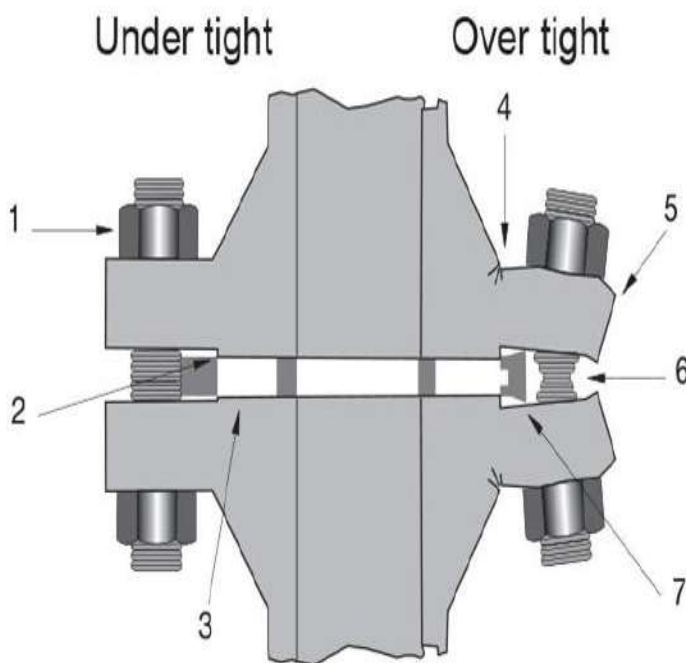

Advantages of Controlled Tightening **Safe operation following prescribed procedures**

Eliminates the dangerous activities of manual uncontrolled tightening and requires that the operators be skilled and follow procedures.

Reduces operational time resulting in increased productivity

Reduces tightening time and operator fatigue by replacing manual effort with the use of controlled tooling.

Reliable and repeatable results

Using calibrated, tested equipment, following procedures and employing skilled operators achieves known results consistently.

The right results first time

Many of the uncertainties surrounding in-service joint failures are removed by ensuring the correct assembly and tightening of the joint are carried out the first time.

AT TUFF OUR FASTENERS EXHIBITS BETTER COEFFICIENT OF FRICTION TO PROVIDE SUPERIOR TIGHTENING AND GRIPPING.

Frequently asked Questions:

Q. Why we lubricate Fasteners?

A. Lubrication makes surface smooth, reduce friction factor, torque loss minimized & controlled, required tension of the bolt achieved. As per required it is advised to use Lubrication oil of such quality which get dry after fitment.

Q. What is the difference between a common bolt and High Tensile Bolt?

A. Ordinary bolts are generally made of ordinary steels. These bolts can be used again and again. Ordinary bolts usually belong to 4.4, 4.8 and 5.6 grades whereas high tensile bolts belong to 8.8 & 10.9 grades in general. High Tensile bolts have large load bearing capacity as compared to ordinary bolts.

Q. What is the Difference between heavy hex bolt and hex bolt?

A. The difference between a heavy hex bolt and a regular hex bolt is the distance across flat of the hex. Heavy hex bolts are 1/8 of an inch larger than a finished hex bolt of the same diameter. The formula for determining hex size is one-and-a-half times the diameter plus 1/8".

Q. What is the role of documentation in fastener supply?

A. The certification process of fasteners-the inbound and outbound exchange of certifications. Documentation during supply results in traceability and efficiency.

Q. What types of bolts are used in Industry?

A. Heavy hex bolts, hex bolt, Allen key bolt, countersunk head bolt, Tension control bolt, Lock bolt, etc many more types using in industry. Their high strength properties

properties results its uses widely in the different types of industries.

Q.What is ISO/IEC 17025 Certification?

A. ISO (International Organization for Standardization) / IEC (International Electro technical Commission) is an international standard having code ISO/IEC 17025 addresses the General requirements for competence of Testing and Calibration Laboratories. The testing and Calibration laboratories get formal accreditation by demonstrating their capability and competency to deliver reliable results meeting the requirement of this standard. ISO/IEC 17025-2017 is the latest applicable version.

Q. What is Pioneer's strength to maintain consistent quality requirements ?

At Pioneer being our start of the carrier in early 1980's was Heat Processing unit. HERO HONDA and MARUTI SUZUKI were our customers then while working with Japanese standard requirements we learnt importance of documentation and Zero tolerance in quality. As closely we are working on metals and metallurgy from last 30 years, now which is our core area of expertise.

Thank You



2
0
2
2

MAY

Sun	Mon	Tue	Wed	Thu	Fri	Sat
1	2	3				
8	9	10	4	5	6	7
15	16	17	11	12	13	14
22	23	24	18	19	20	21
29	30	31	25	26	27	28

JUNE

Sun	Mon	Tue	Wed	Thu	Fri	Sat
				1	2	3
5	6	7	8	9	10	11
12	13	14	15	16	17	18
19	20	21	22	23	24	25
26	27	28	29	30		

JULY

Sun	Mon	Tue	Wed	Thu	Fri	Sat
					7	1
3				2		
10	4	5	6	14	8	9
17	11	12	13	21	15	16
24	18	19	20	28	22	23
31	25	26	27		29	30

AUGUST

Sun	Mon	Tue	Wed	Thu	Fri	Sat
	1	2	3	4	5	6
7	8	9	10	11	12	13
14	15	16	17	18	19	20
21	22	23	24	25	26	27
28	29	30	31			

SEPTEMBER

Sun	Mon	Tue	Wed	Thu	Fri	Sat
				1	2	3
4	5	6	7	8	9	10
11	12	13	14	15	16	17
18	19	20	21	22	23	24
25	26	27	28	29	30	

OCTOBER

Sun	Mon	Tue	Wed	Thu	Fri	Sat
	2	3				1
9	10	4	5	6	7	8
16	17	11	12	13	14	15
23	24	18	19	20	21	22
30	31	25	26	27	28	29

NOVEMBER

Sun	Mon	Tue	Wed	Thu	Fri	Sat
		1	2	3	4	5
6	7	8	9	10	11	12
13	14	15	16	17	18	19
20	21	22	23	24	25	26
27	28	29	30			

DECEMBER

Sun	Mon	Tue	Wed	Thu	Fri	Sat
					1	2
4	5	6	7	8	9	10
11	12	13	14	15	16	17
18	19	20	21	22	23	24
25	26	27	28	29	30	31

2
0
2
3

JANUARY

Sun	Mon	Tue	Wed	Thu	Fri	Sat
1	2	3				
8	9	10	4	5	6	7
15	16	17	11	12	13	14
22	23	24	18	19	20	21
29	30	31	25	26	27	28

FEBRUARY

Sun	Mon	Tue	Wed	Thu	Fri	Sat
5	6	7	1	2	3	4
12	13	14	8	9	10	11
19	20	21	15	16	17	18
26	27	28	22	23	24	25

MARCH

Sun	Mon	Tue	Wed	Thu	Fri	Sat
					1	2
5	6	7	8	9	10	11
12	13	14	15	16	17	18
19	20	21	22	23	24	25
26	27	28	29	30	31	

APRIL

Sun	Mon	Tue	Wed	Thu	Fri	Sat
						1
9	3	4	5	6	7	8
16	10	11	12	13	14	15
23	17	18	19	20	21	22
30	24	25	26	27	28	29

MAY

Sun	Mon	Tue	Wed	Thu	Fri	Sat
	1	2	3			
7	8	9	10	4	5	6
14	15	16	17	11	12	13
21	22	23	24	18	19	20
28	29	30	31	25	26	27

JUNE

Sun	Mon	Tue	Wed	Thu	Fri	Sat
				1	2	3
4	5	6	7	8	9	10
11	12	13	14	15	16	17
18	19	20	21	22	23	24
25	26	27	28	29	30	

JULY

Sun	Mon	Tue	Wed	Thu	Fri	Sat
	2	3				1
9	10	4	5	6	7	8
16	17	11	12	13	14	15
23	24	18	19	20	21	22
30	31	25	26	27	28	29

AUGUST

Sun	Mon	Tue	Wed	Thu	Fri	Sat
		1	2	3	4	5
6	7	8	9	10	11	12
13	14	15	16	17	18	19
20	21	22	23	24	25	26
27	28	29	30	31		

SEPTEMBER

Sun	Mon	Tue	Wed	Thu	Fri	Sat
					1	2
3	4	5	6	7	8	9
10	11	12	13	14	15	16
17	18	19	20	21	22	23
24	25	26	27	28	29	30

OCTOBER

Sun	Mon	Tue	Wed	Thu	Fri	Sat
	1	2	3			
8	9	10	4	5	6	7
15	16	17	11	12	13	14
22	23	24	18	19	20	21
29	30	31	25	26	27	28

NOVEMBER

Sun	Mon	Tue	Wed	Thu	Fri	Sat
				1	2	3
5	6	7	8	9	10	11
12	13	14	15	16	17	18
19	20	21	22	23	24	25
26	27	28	29	30		

DECEMBER

Sun	Mon	Tue	Wed	Thu	Fri	Sat
						3
10	4	5	6	7	8	9
17	11	12	13	14	15	16
24	18	19	20	21	22	23
31	25	26	27	28	29	30

HOLIDAYS

JAN.

13th Lohri
14th Makar Sankranti
26th Republic day
26h Basant Panchmi

FEB.

5th Satguru Ravidas Jyanti
18th Maha Shivratri

MAR.

6th Holi
7th Dhulendi
30th Ram Navami

APR.

4th Mahavir Jyanti
6th Hanuman Jyanti
7th Good Friday
14th Ambedkar Jyanti
22th ID-JL-Fitar

MAY

5th Budh Purnima

JUN

29th ID-JL -Azha

JUL.

29th Moharram

AUG.

15th Independence Day
30th Raksha Bandhan

SEP.

6th Janamastmi
19th Ganesh Chaturthi
28th Anant chaturthi
29th Id-e-Milad

OCT.

2nd Gandhi Jayanti
24th Dushehara
28th Balmiki Jayanti

NOV.

12th Diwali
13th Goverdhan Pooja
15th Bhaiya Dooj
27th Gurunanak Birthday

DEC.

25th X'mas Day

Not Responsible for Holiday Please compare with Govt. Gazette



2
0
2
4

JANUARY

Sun	Mon	Tue	Wed	Thu	Fri	Sat
	1		3	4	5	6
7	8		10	11	12	13
14	15		17	18	19	20
21	22		24	25	26	27
28	29		31			

FEBRUARY

Sun	Mon	Tue	Wed	Thu	Fri	Sat
	5	6	7	1	2	3
4	12	13	14	8	9	10
11	19	20	21	15	16	17
18	26	27	28	22	23	24
25				29		31

MARCH

Sun	Mon	Tue	Wed	Thu	Fri	Sat
	3	5	6	7	1	2
10	4	12	13	14	8	9
17	11	19	20	21	15	16
24	18	26	27	28	22	23
31	25				29	30

APRIL

Sun	Mon	Tue	Wed	Thu	Fri	Sat
	1	2	3	4	5	6
7	8	9	10	11	12	13
14	15	16	17	18	19	20
21	22	23	24	25	26	27
28	29	30				

MAY

Sun	Mon	Tue	Wed	Thu	Fri	Sat
	6	7	1	2	3	
5	13	14	8	9	10	4
12	20	21	15	16	17	11
19	27	28	22	23	24	18
26			29	30	31	25

JUNE

Sun	Mon	Tue	Wed	Thu	Fri	Sat
	2	3	4	5	6	7
9	10	11	12	13	14	8
16	17	18	19	20	21	15
23	24	25	26	27	28	22
30						29

JULY

Sun	Mon	Tue	Wed	Thu	Fri	Sat
	1	2	3	4	5	6
7	8	9	10	11	12	13
14	15	16	17	18	19	20
21	22	23	24	25	26	27
28	29	30	31			

AUGUST

Sun	Mon	Tue	Wed	Thu	Fri	Sat
	5	6	7	1	2	3
4	12	13	14	8	9	10
11	19	20	21	15	16	17
18	26	27	28	22	23	24
25				29	30	31

SEPTEMBER

Sun	Mon	Tue	Wed	Thu	Fri	Sat
1	2					
8	9	3	4	5		7
15	16	10	11	12		14
22	23	17	18	19		21
29	30	24	25	26		28

OCTOBER

Sun	Mon	Tue	Wed	Thu	Fri	Sat
	7	1	2	3	4	5
6	14	8	9	10	11	12
13	21	15	16	17	18	19
20	28	22	23	24	25	26
27		29	30	31		

NOVEMBER

Sun	Mon	Tue	Wed	Thu	Fri	Sat
					1	2
3	4	5	6	7	8	9
10	11	12	13	14	15	16
17	18	19	20	21	22	23
24	25	26	27	28	29	30

DECEMBER

Sun	Mon	Tue	Wed	Thu	Fri	Sat
	1	2	3			
8	9	10	4	5	6	7
15	16	17	11	12	13	14
22	23	24	18	19	20	21
29	30	31	25	26	27	28

HOLIDAYS

JANUARY	FEBRUARY	MARCH	APRIL	MAY	JUNE
14th Lohri 15th Makar Sankranti 26th Republic day	14th Basant Panchmi 24th Satguru Ravidas Jyanti	8th Maha Shivratri 25th Holi 25th Dhulendi 29th Good Friday	9th & 10th ID-UL-Fitar 17th Ram Navami 21st Mahavir Jayanti 23rd Hanuman Jayanti	23th Budh Purnima	16th & 17th ID-UL-Azha
JULY	AUGUST	SEPTEMBER	OCTOBER	NOVEMBER	DECEMBER
17th Moharram	15th Independence Day 19th Raksha Bandhan 26th Janamashtmi	7th Ganesh Chaturthi 16th Anant Chaturdashi 20th Id-e-Milad	2nd Gandhi Jayanti 12th Dussehra 17th Balmiki Jayanti	30th Diwali 2nd Govardhan Pooja 3rd Bhaiya Dooj 15th Guru Nanak Birthday	25th X'Mas Day

Not Responsible for Holiday Please compare with Govt. Gazatte



Pioneer Nuts & Bolt Pvt. Ltd. is First fasteners manufacturing company in India to get ZED GOLD certificate From Central Minister of MSME Narayan Rane ji



About Us

Pioneer nuts and bolts is an ISO 9001:2015 TUV certified company having its registered office in Ludhiana, INDIA. The company was established by late Shri Joginder Kumar Gupta in 1996. Now the company manufactures full range of industrial fasteners with critical, metallurgical and drawing requirements. We are the first in our region to have an IEC/ISO 17025 accredited laboratory covering both chemical and mechanical scope.